



# FLATTILE

*Straight steel tile!*

- **Easy** construction.
- **Attractive** design.
- **30 years** warranty.
- **Renovation – New buildings.**
- **Lightweight** tile (6.64 kg/m<sup>2</sup>).
- Can be installed upon **existing roofs.**
- **Acoustic comfort** with "Flattile" Thermo.



# FLATTILE

*Straight steel tile!*

Flattile is an advanced roofing system comprising coated zinc aluminium galvanised steel tile panels. It's **high resistance** is designed to resist even the most extreme weather conditions.

## TECHNICAL INFORMATION :

### Weight

Weight per m <sup>2</sup> :	6,64 kg
Weight per tile :	2.45 kg
Weight per pallet (130 m <sup>2</sup> ) :	882,0 kg

### Dimensions

Size of tile – overall :	1265 mm x 350 mm
Size of tile – cover :	1215 mm x 304 mm
Gauge :	304 mm
Linear cover width :	1215 mm
Coverage per tile :	0.37 m <sup>2</sup>
Coverage :	2.71 tile per m <sup>2</sup>

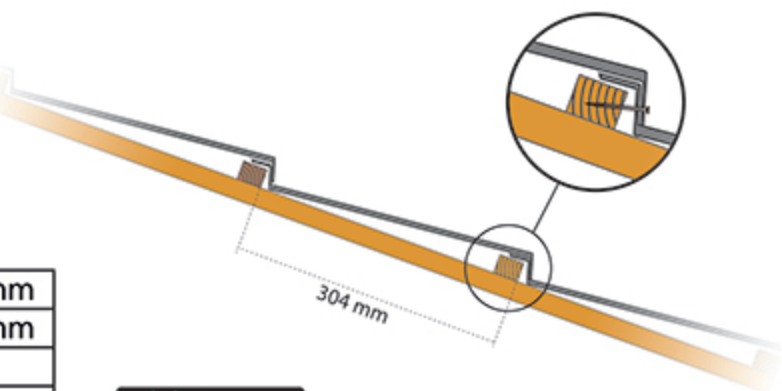

### Fixings

Tile Fixings :	special A-Nails, 50 mm x 2.5 mm
Fixings :	per tile 3no

## COLOURS :



grey mat



black mat



rustic red



black brillant

**Flattile Thermo**, a noise reducing version, is also available.

A broad range of adapted accessories completes the system which enhances a perfect finishing of the roof. Manufacturer's warranty : 30 years

**GVPRODUCTS N.V.**

Bilzersteenweg, 43  
3770 Riemst (Belgium)  
Mail : [gv.products@skynet.be](mailto:gv.products@skynet.be)

Tel : +32 12 44 14 44  
Fax : +32 12 44 14 45  
Website : [www.alcotile.be](http://www.alcotile.be)